

35-46 Sump Valve - 1947 Scraper - 1948-53 Pick Up

Oil Scraper 1947

No.	Part No.	Description (Scraper)	
1	24B16	Elbow	47-53
2	24B17	Nut: Elbow lock	47-53
3	A21120	Washer: Sealing	47-53
4	751609-K	Screw kit: Scraper to crankcase	1947
5	182002	Scraper	1947
6	454016-S	Gasket: Scraper to crankcase	1947
6	454016-SR	Gasket: Cometic	1947

Note: Early 1948 models came with a 182002 scraper

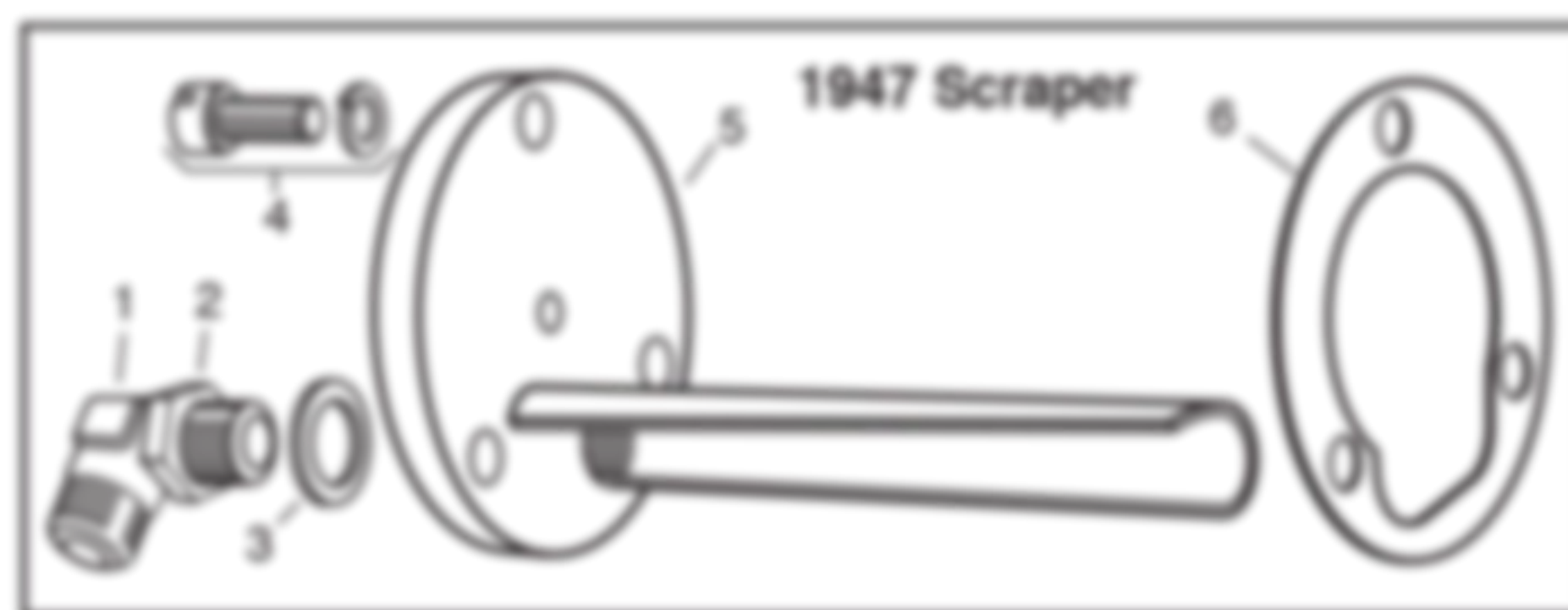

Oil Pick-up 48-53

No.	Part No.	Description (Scraper)	
1	24B16	Elbow	48-53
2	24B17	Nut: Elbow lock	48-53
3	A21120	Washer: Sealing	48-53



Oil Sump Valve 35-46

No.	Part No.	Description (Sump Valve)	Year
1	24B16	Elbow	22-53
2	24B17	Nut: Elbow lock	22-53
3	A21120	Washer: Sealing	22-53
4	39888	Housing	35-46
5	43275	Screen	35-46
6	39891	Gasket: Housing	35-46
6	39891-R	Gasket: Housing, Cometic	35-46
7	43115-K	Screw: 8-32 x 7/16"	35-46
8	43115-K	Lock washer: Split #8	35-46
9	43115	Bracket: Spring support	35-46
10	40208	Spring: Sump valve disc	35-46
11	41530	Disc: Sump valve	35-46
12	43277	Plate w/tube	35-46
13	750205-K	Screw kit: 8-32 x 3/8" FH	35-46
14	454016	Gasket: Sump	35-46
14	454016-R	Gasket: Sump, Cometic	35-46
15	751612-K	Screw kit: 1/4-20 x 7/8"	35-46
16	751612-K	Screw kit: Split L/W 1/4"	35-46

