

EXHAUST

No.	Part No.	Description	Year
1	641010	Header: Chrome	46-51
2	641012	Muffler: Chrome	46-51
3	829009	Strap: Header to frame mounting	46-53
4	800012	Spacer: Muffler clamp to frame	40-51
5	641023	Header: Chrome	52-53
6	593005	Muffler: Chrome (without fishtail)	52-53
7	641022	Fishtail: Chrome	52-53
8	93120	Header: Front, bare finish, incl joiner	40-45
9	42577	Joiner: Header	40-45
10	93176	Muffler: Plain finish	40-45
11	92368/70	Exhaust system: Complete	33-38
12	92368/39	Exhaust system: Complete	1939

Note: 33-38 and 39 complete exhaust systems includes clamps, brackets & hardware.

13	92370	Muffler: Plain finish, with cut out	33-38
14	92898	Muffler: Plain finish	1939
15	25B388	Clamp: Muffler body to frame	
16	312008	Clamp: Tail pipe to fender	

Note: 25B388 & 312008 clamps fit older 40-51 replacement systems as suppliers didn't make them correctly as we do so today (welded on).

17	KI-10500	Heat shield: Saddlebag, chrome. Saves saddlebags from touching the tail pipe and burning a hole in your nice saddlebags.	40-51
----	----------	--	-------

Note: Throughout our manufacturing process we ensure our exhausts fit properly when used together as a set. There can be variations to your Indian that are beyond our control. This is not the fault of the exhaust itself as each cylinder can move around on the crankcase during assembly, factory exhaust port outlet machining can vary, engine fit into the frame, tweaked frames and so on. These are all beyond our control but rest assured I have done everything possible from a manufacturing and experience stand point to ensure a proper fit

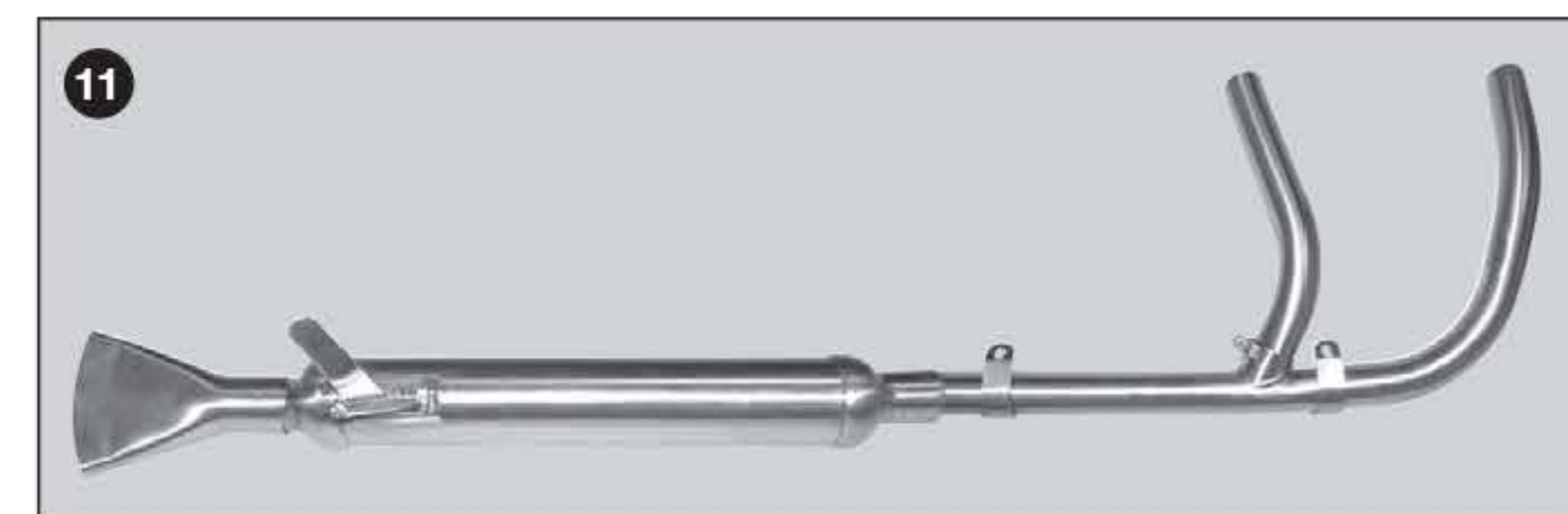
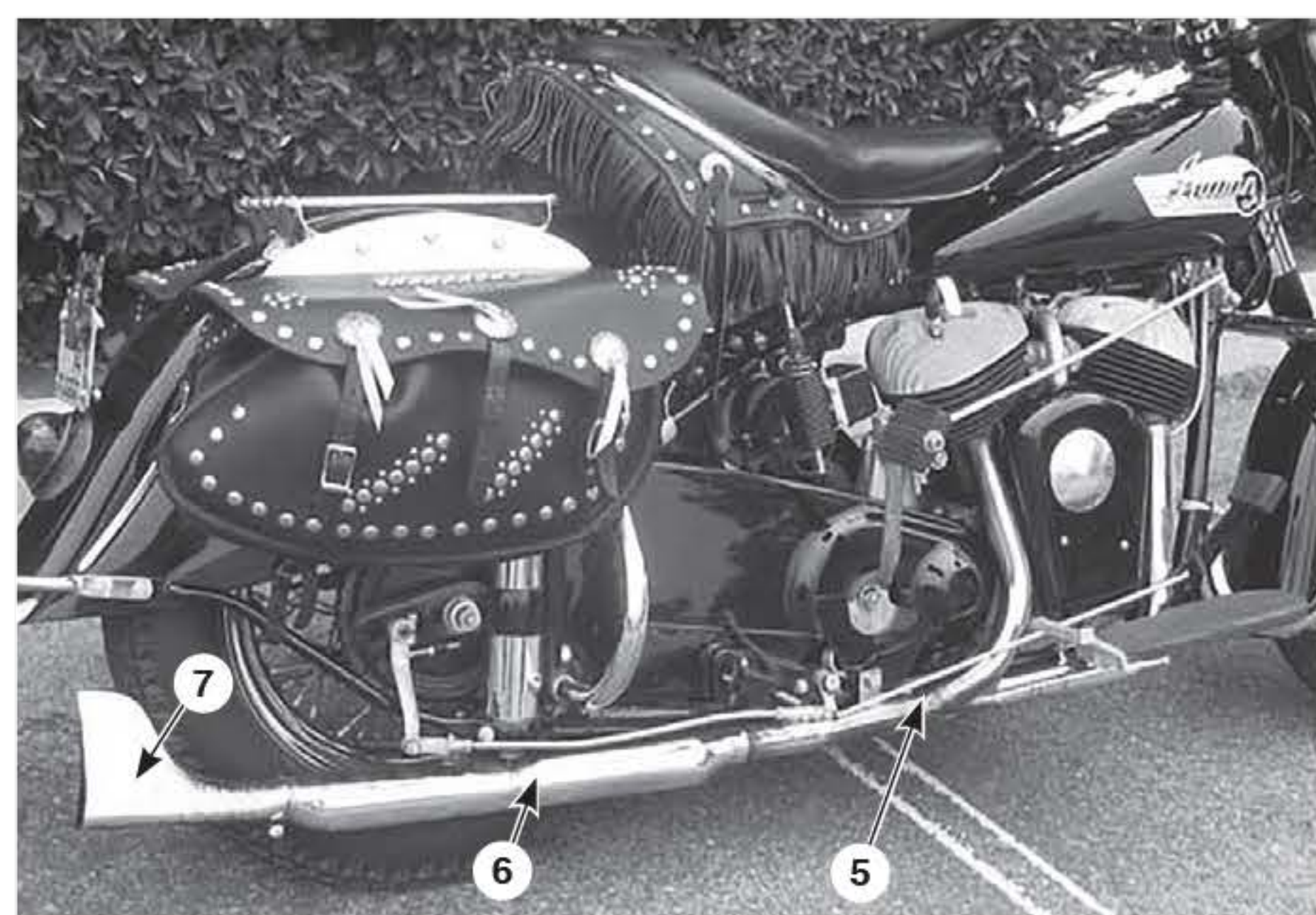
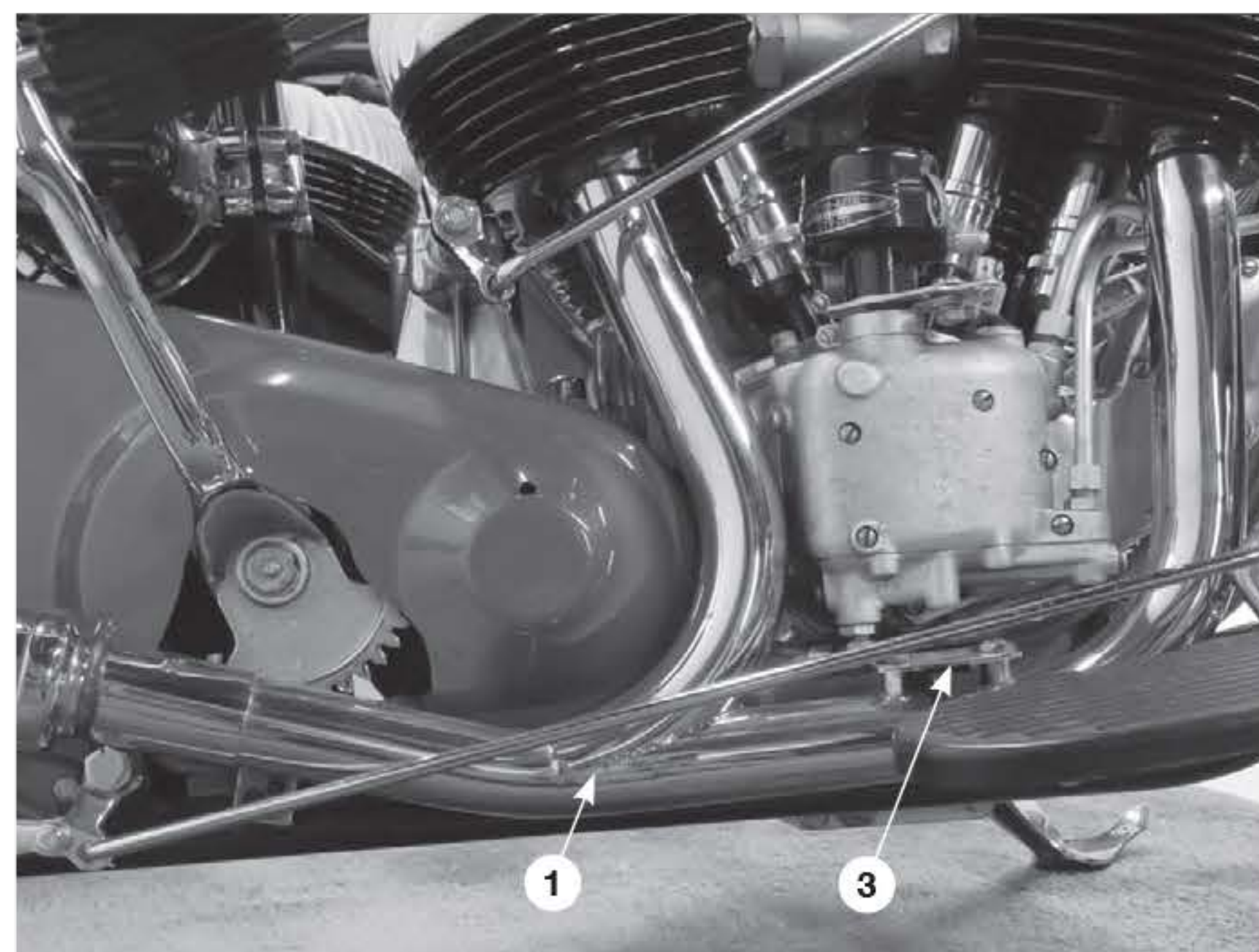

EXHAUST

Fits both 1940-42 skirted fender models and 40-45 Military/Essential use (open fender) models.

